

Accu-Count Tabber™

Featured Benefits

- Reduces costs by eliminating unnecessary overruns
- Up to 50% reduction in manning by eliminating manual weighing or counting in typical stacking operations
- Verified accurate counts build confidence in your customers
- Accurate count bundles greatly improve overall pallet integrity
- Elimination of costly secondary counting & batching operations off-line
- Small batch counts now attainable on-line at significant savings
- Mail sortation applications capability eliminate mail sort costs
- Simple, reliable design, easy to install, operate, move and maintain
- Small footprint- allows easy integration into any existing line
- Custom multi-stream versions available
- Total lock casters allow easy transport from one line to another
- Top registration of stream automatically accommodates varying stream thickness without any changeover
- Closed-loop control system ensures repeatable label placement, regardless of variations in shingle spacing or speed
- Wide range of infeed/exit heights and angles easily adapt to any line

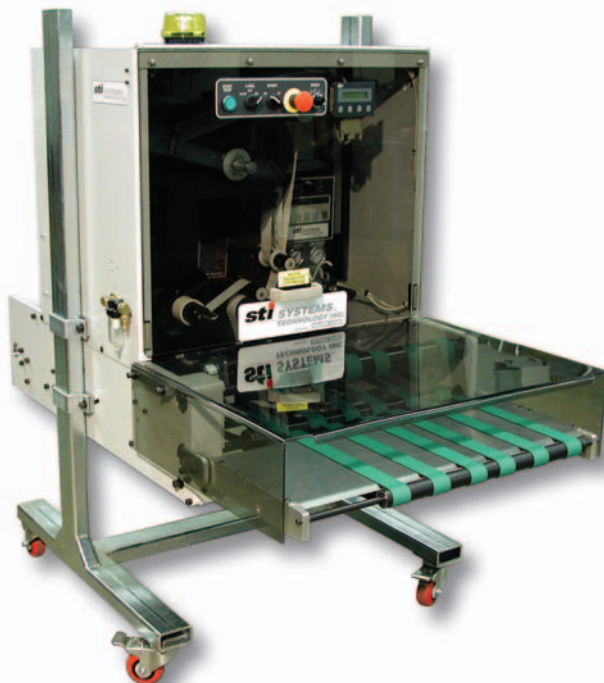

The **Accu-Count Tabber™** (ACT) is an innovative stand-alone system that is designed to deliver truly accurate counts of printed products even when delivered in the highest speed applications. The **Accu-Count Tabber** utilizes a proprietary design peel-off, non-marking adhesive label that, when processed through this patent applied for system, allows the label to be precisely and accurately applied to the leading edge of the printed product that has been counted by the laser sensor in the system, without adhering to the next product.

The system automatically compensates for variations in shingle overlap, thickness and speed, with virtually no user intervention. It is intended for applications where exact count is crucial to the operations, such as in in-line finishing, mail sortation, pressroom stacker needs, and bindery lines.

A shingled stream of products enters the system and passes under a high-speed laser sensor which enables highly accurate counting of the product. A specialized label applicator then precisely applies the peel-off label onto the leading edge of the product which corresponds to the desired pre-set count. The shingled stream is securely trapped between upper and lower belts that automatically adjust for the shingle thickness. The product stream exits the system with the labels securely attached, for further processing by a stacker or other downstream sortation processes.



The label can either be easily removed by the operator or it can be removed at any time in the future without any ink transfer or damage to the product. The label can be optionally printed with any customized marketing logo or message based on customer requirements.

Systems Technology Inc.

1351 E. Riverview Dr. • San Bernardino • CA 92408 USA • Tel: 909.799.9950 • Fax: 909.796.8297
www.systems-technology-inc.com

Accu-Count Tabber™

STANDARD SPECIFICATIONS

Product	Minimum	Maximum
Product Width "A"	76mm (3.00")	483mm (19.00")
Product Length "B"	38mm (1.50")	550mm (21.65")
Shingle Overlap "C"	25mm (1.00")	
Product Pagination (single product)	2 pages	250 Pages
Shingle Thickness	.1mm (.004")	51mm (2.00")
Product Orientation	Spine leading, spine on the side, spine trailing	
Label Size	19mm x 32mm (.50" x 1.25")	
Label Placement (A-direction)	0-76mm (0-3.00") from center of product (+/- 1.5mm (.06"))	
Label Placement (B-direction)	16mm (.63") outside leading edge (+/- 3mm (.13"))	
Labeling Rate*	Standard Unit 0-50 ft/min: Every product 51-100 ft/min: Every 5 products 101-150 ft/min: Every 10 products 151-200 ft/min: Every 15 products 201-250 ft/min: Every 20 products 251-350 t/min: Every 30 products High-Speed Unit 0-100 ft/min: Every product 101-200 ft/min: Every 5 products 201-350 ft/min: Every 10 products	
Label Roll	305mm (12.00") dia, 24,000 labels	

* Assumes 1" shingle spacing

Machine:

Operating Speed (Adjustable)	0-107m/min (0-350ft/min)
Input Power	120 VAC 1ph, 50/60Hz
Press Speed Following	0-10VDC
Air Requirement	185 Norm- l/min (6cfm @80psi)
Air Pressure	6 bar (80psi)
Overall Length*	926mm (36.44")
Overall Width	794mm (31.25")
Infeed and Exit Height	229mm-1168mm (9.00"-46.00")
Conveyor Angle	+/- 12deg (products permitting)
Weight	182 kg (400 lb)
Paint Color	RAL 7035 (Light Grey)

*Optional divert would increase length to 1281mm(50.44")



Tab inserted on signature in the shingled stream at exact count



Tabs act as flags to locate the start and finish of the exact count

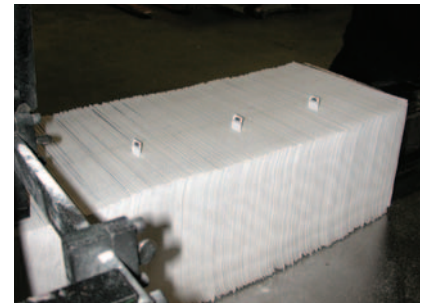

Tabs can be placed at any count

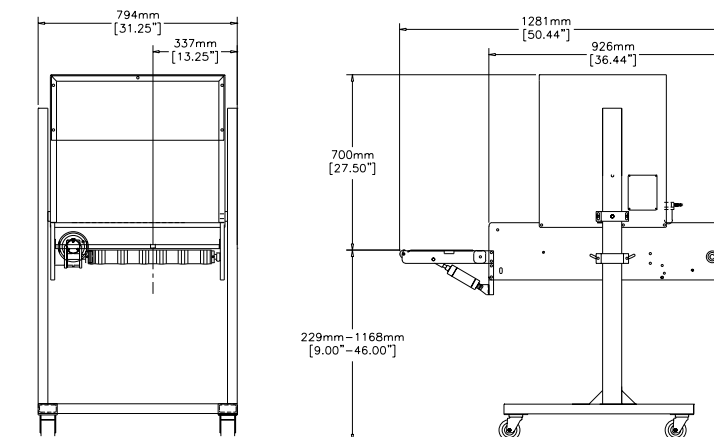

Systems Technology Inc. reserves the right to change specifications without notice.
This equipment covered by U.S. and Foreign Patents and Patents applied for.